

Industrial remote control



Precautions of Operation

ATTENTION

- ⊗ Never dismantle the equipment by any unauthorized personnel, or equipment may be damaged.
- ⊗ This manual is for reference only. Please consult your distributor for further assistance.
- ⊗ The equipment has been strictly tested for quality before delivery from our plant. However, this equipment must not be used in dangerous situations or where damage may result.
- ⊗ After operation, shut off main power to the crane, power to receiver, and remove transmitter key.
- ⊗ Transmitter should be placed in a safe area when not in use to avoid accidental pressing of buttons.
- ⊗ The crane should be equipped with main power relay, limit switch and other safety devices.
- ⊗ Don't use equipment during lightning or high electrical interference conditions.
- ⊗ Make sure that the batteries are in good condition and power for receiver is correct.
- ⊗ Maintenance should only be done while the crane's main power is off to

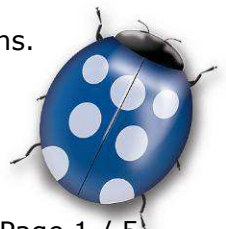

Date: 09.07.2013

Page 1 / 5

Molpir s.r.o. sídlo: SNP 129, 919 04 Smolenice; prevádzka: Hrachová 30, 821 05 Bratislava, Slovenská republika, Tel.: 00421 2 4319 1219, Fax: 00421 2 4319 1220, e-mail: obchod@molpir.com, www.molpir.com, www.shop.molpir.com

IČO: 31431372, IČpD: SK 2020391560, Tatra banka Bratislava, č. ú.: 2628020575/1100, register: OS Trnava, odd: Sro, vlož.: 1045/T

MOLPIR GROUP CZ a.s., Technologická 838/14, 779 00 Olomouc, Holice, Česká republika, Tel.: 00420 585 315 017, Fax: 00420 585 315 021, e-mail: molpir_o@molpir.cz, www.molpir.cz

MOLPIR GROUP CZ a.s., Business centrum Klamovka, Plzeňská 155/113, 150 00 Praha 5 – Košíře, Tel.: 00420 724 606 000, e-mail: jsvoboda@molpir.cz, www.molpir.cz

IČO: 25828843, DIČ: CZ25828843, ČSOB Olomouc, č. ú.: 377913723/0300, Registrace: KOS, OR Ostrava, oddíl B, vložka č. 2094

- prevent electrical shock.
- ⊗ The contents of this manual may be amended by the manufacturer without notice.
- ⊗ The manufacturer may introduce new functions to the equipment as necessary, therefore, the descriptions may change.

PRECAUTIONS

1. Operating in industrial facility is relatively dangerous; therefore, operator must have taken the adequate trainings in using F25 system.
2. Those who operate the machine should be healthy and have good judgment in regard to safety.
3. Although the F25 transmitter is so durable and resistant for the fluctuating temperature, care still need be taken to prevent it from the severe impact or pressure.
4. If the severe interference occurred the equipment should be stopped at once.
5. Please take the batteries out when the equipment will not be used for a long time.
6. Be sure to know the „Procedures of Emergency“ as follows.

PROCEDURES OF EMERGENCY

In case of an Emergency, please follow the steps below and ask the distributor for service immediately.

1. Press „EMS“ button.
2. Turn the key to „OFF“ position and remove it.
3. Switch off the main power of crane.
4. Advise the distributor to find out the reason.



OPERATION

When you acquire a standard and full set of F25 system, it includes the following items, Transmitter and Receiver. The overview of transmitter and receiver are as follows:



OPERATION

1. Install four AA size batteries in the transmitter and make sure the „+“ and „-“ direction are correct.
2. Insert the rotary key into the keyhole at „OFF“ position and then turn clockwise to „ON“ position.
3. Press the „START“ pushbutton to Power-On.
NOTE: If fail to follow the procedure above, the LED light will indicate fast flashing in red.
4. Operate normally according to the function setting has done.

OPERATION

Please proceed the following procedure after operation.

1. Press EMS mushroom.
2. Turn the rotary key to „OFF“ position.
3. Remove the rotary key.
4. Remove the batterie s when the equipment is not going to be used for a long period of time.



USAGE OF TRANSMITTER BATTERY

1. There is a 3-stage power indicating function with LED display.
 - (1) „Green color“: Sufficient power to operate transmitter.
 - (2) „Yellow color“: Power is depleting. Operation must be stopped immediately (for example: down the loads to ground) to replace batteries.
 - (3) „Red color“: Insufficient power. Transmitter will send out an emergency stop signal to the receiver due to insufficient power. Operator should avoid this situation in order to maintain the safety of operation.
2. **Turn the rotary key of the transmitter to „OFF“ position; it will not only shut off the motion of the receiver but also save the power. Otherwise, the transmitter will keep staying in the standby mode and causing more power consumption.**

RECEIVER POWER SUPPLY

F25 receiver provides with 4 kinds of Transformer (24V/42V/230V; 48V/110V/220V; 110V/220V/380V; 48V/220V/380V) that allows user to choose based on the power input on site and the designated voltage will be set when the receiver is made in factory.

OPERATION



Fig.3



Fig.4

CHANGING POWER SUPPLY VOLTAGE

1. Disconnect the power of receiver.
2. Remove the connector plug of the transformer from its original position, see Fig.1.
3. Insert the connector plug into the new position, see Fig.2.



4. Complete the procedure.

NOTE: Users are allowed to select the different power source according to the respective requirement. However, the transformer must be changed. Please check with your local distributor for replacement of the transformer if necessary.

INSPECTION AND FAULT DETECTION

Daily inspection is important and will ensure the safety of operation. Inspection should include „emergency stop“ and other safety devices and functions. If there is any doubt, operation must be stopped immediately and problems must be solved before resume of operation.

FAULT DETECTION

F25 is equipped with simple fault detection mechanism. While start and during the operation, fault detection mechanism will indicate the faulty signals if any malfunction is detected. Operator must understand the faulty signals and notify the maintenance personnel.

TRANSMITTER FAULT DETECTION

If the LED light on the transmitter is fast flashing in red, then there must be the causes as follows:

1. Some of the push buttons are jammed or stock....
2. EMS button has not been released.
3. Fail to follow the correct Power-ON procedure.

WIRING DIAGRAM

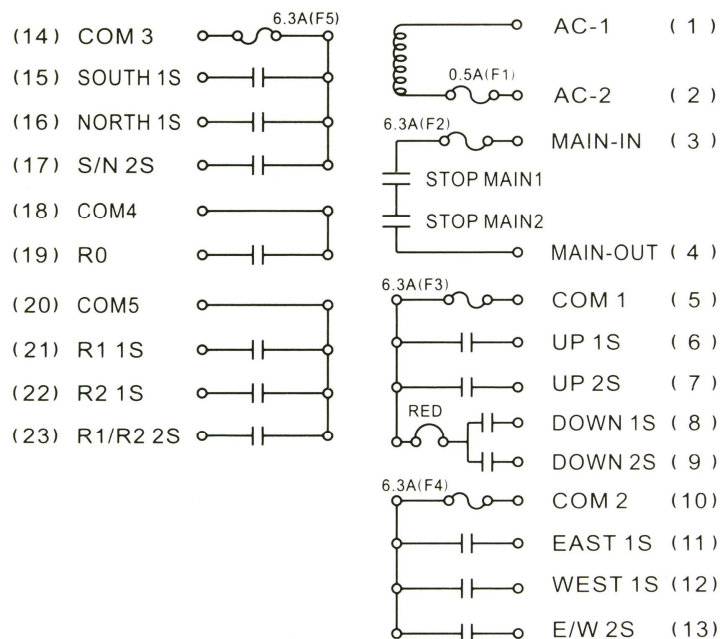

Date: 09.07.2013

Page 5 / 5

Molpir s.r.o. sídlo: SNP 129, 919 04 Smolenice; prevádzka: Hrachová 30, 821 05 Bratislava, Slovenská republika, Tel.: 00421 2 4319 1219, Fax: 00421 2 4319 1220, e-mail: obchod@molpir.com, www.molpir.com, www.shop.molpir.com

IČO: 31431372, IČpD: SK 2020391560, Tatra banka Bratislava, č. ú.: 2628020575/1100, register: OS Trnava, odd: Sro, vlož.: 1045/T

MOLPIR GROUP CZ a.s., Technologická 838/14, 779 00 Olomouc, Holice, Česká republika, Tel.: 00420 585 315 017, Fax: 00420 585 315 021, e-mail: molpir_o@molpir.cz, www.molpir.cz
MOLPIR GROUP CZ a.s., Business centrum Klamovka, Plzeňská 155/113, 150 00 Praha 5 – Košíře, Tel.: 00420 724 606 000, e-mail: jsvoboda@molpir.cz, www.molpir.cz

IČO: 25828843, DIČ: CZ25828843, ČSOB Olomouc, č. ú.: 377913723/0300, Registrace: KOS, OR Ostrava, oddíl B, vložka č. 2094